

Tumble dryer

T4900, T41200

Features and benefits

- High productivity - 2 full loads per hour
- Selection of temperature and time for easy operation
- Large door opening for easy loading and unloading
- Large selfcleaning lint screen for easy maintenance
- Easy access to vital parts from front and rear for simple servicing
- Selecta microprocessor control
- Reversing drum
- Emergency stop
- Supply disconnecter
- Gas reset from front (gas version)

Main options

- Stainless steel front
- Stainless steel drum
- Frequency controlled motor
- Fresh air intake
- Indicator lamp for finished drying cycle
- RMC (Residual Moisture Control)
- Sliding door (separate data sheet)
- Tilting forward (separate data sheet)
- CMIS



Images shown are a representation of the product only and variations may occur.

Main specifications			T4900				T41200			
Rated capacity, filling factor 1:20	kg/lb		45/100				60/132			
		kg/lb	36/80				48/105			
Drum volume		litre	900				1200			
Drum diameter		mm	1240				1240			
Heating alternatives	gas	BTU/h (kW)	218 430 (64)				279 865 (82)			
	steam at 700 kPa		82				82			
	el	kW	48/60				60/72			
Consumption data*			Gas	Steam	EI 48 kW	EI 60 kW	Gas	Steam	EI 60 kW**	EI 72 kW**
Total time at 45/60 kg		min	26	31	35	28	27	34	35	26
Energy consumption at 45/60 kg		kWh	26.2	43.5	27.4	28	35.6	49	34.8	30.8
Evaporation		g/min	865	735	651	803	1070	876	854	923
Energy kWh/litre water evaporated		kWh/l	1.16	1.91	1.2	1.2	1.23	1.64	1.17	1.28

* At rated capacity 100% cotton load at 50% initial moisture dried to 0%.

** Test load 48 kg/100 lbs.

Produced according to ISO 9001 and ISO 14001.

Certified with CB certificate for Low Voltage Directive and S-mark according to the Machinery Directive. Protection class IP X4D.

Electrical connections*			T4900	T41200
HeatingVoltage				
EI	230-240V 3 AC 50/60 Hz	kW(A)	51 (160)	-
	400-415V 3 AC 50 Hz	kW(A)	51 (80)	63 (100)
	400-480V 3 AC 60 Hz	kW(A)	51 (80)	63 (100)
	400-415V 3 AC 50 Hz	kW(A)	63 (100)	75 (125)
Gas or steam	400-480V 3 AC 60 Hz	kW(A)	63 (100)	75 (125)
	200-240V 3 AC 50/60 Hz	kW(A)	3.3 (20)	3.3 (20)
	400-415V 3 AC 50 Hz	kW(A)	3.3 (16)	3.3 (16)
400-480V 3 AC 60 Hz	kW(A)	3.3 (16)	3.3 (16)	
Steam, gas and air connections				
Steam	ISO 228/1-G1		1"	1"
Steam pressure		kPa	100-1000	100-1000
Steam consumption		kg/h	143	143
Condensate	ISO 228/1-G1		1"	1"
Gas	ISO 7/1-R1		1"	1"
Gas pressure	Natural gas	Pa	2000	2000
		mbar	20	20
	Propane	Pa	2800-5000	2800-5000
		mbar	28-50	28-50
Air outlet		mm	Ø 315	Ø 315
Evacuated air,	steam	m ³ /h	2300	2500
	gas	m ³ /h	2300	2500
	electric	m ³ /h	2300	2500
Pressure drop		Max. Pa	100	100
Sound levels				
Airborne sound level		dB(A)	<70	<70
Heat emission				
% of installed power, max			15	15
Shipping data				
Heating unit, gas/steam/electric	net, kg		39/50/42	46/50/42
	total net, kg		545	580
Heating unit, gas/steam/electric	crated, kg		69/80/72	76/80/72
	total crated, kg		576	616
Shipping volume, Heating unit	m ³		0.48	0.48
	total, m ³		3.65	4.16
Dimensions in mm				
A	Width		1290	1290
B	Depth		1295	1485
C	Height		2465	2465
D	(with top removed)		1965	1965
E			780	780
F			850	850
G			245	245
H			230	230
I			1590	1590
K			120	120
L			180	180
M			2055	2055
N			410	410
O			2025	2025
P			2360	2360
R			570	570
S			2400	2590
T			1810	1810
1	Control panel	5	Steam connection	
2	Door opening ø 940	6	Condensate connection	
3	Electrical connection	7	Exhaust connection	
4	Gas connection	8	Delivery height	

* Other voltages available see installation manual.

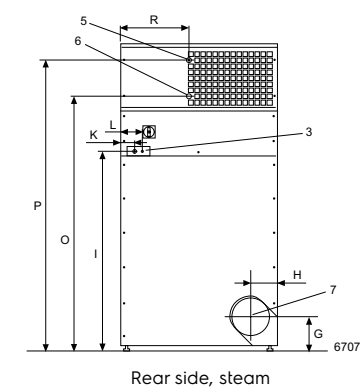
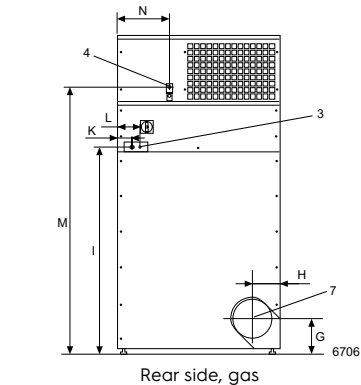
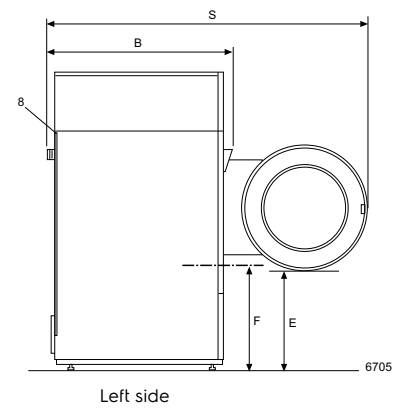
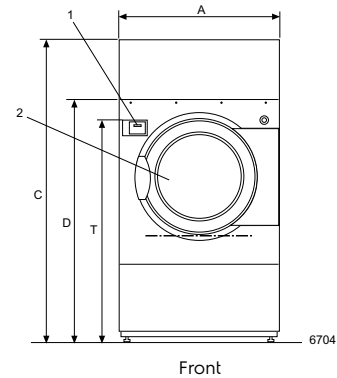

Experience the Excellence
www.electroluxprofessional.com