

we care 

primus

laundry equipment

Professional Washer Extractors Professional Dryers

P 6, P 7

DAM 9, DAMS 9, DAMT 9

DAMS 9

P 6/7



DAM 9

DAMT 9



FEATURES WASHER EXTRACTORS

- Large capacity - 6/7 kg
- Stainless steel cabinet (AISI 304)
- Stainless steel drum and tub
- Easy to use timer, economy programmes, mop programmes
- Short washing cycle
- Large drain valve (Ø50 mm)
- Soap hopper on the front
- Matching dryer available – space saving when placed on top
- Frequency controlled motor
- PowerWash® perforated lifting ribs: more mechanical action, lower water consumption
- SuperEco washing programmes - significantly reduces water and electricity consumption

OPTIONS WASHER EXTRACTORS

- External coin meter
- Drain pump
- Liquid soap pumps

FEATURES DRYERS

- Large capacity – 8 kg
- Large door opening (Ø52 cm)
- Short drying cycle

OPTIONS DRYERS

- External coin meter



COMPACT DESIGN



STACKABLE UNIT



EASY OPERATION

POWERWASH

supereco

TYPE		P6	P7
CAPACITY	kg/lb	6/15	7,5/18
DRUM DIAMETER	mm	Ø530	Ø530
DRUM VOLUME	l	60	73
MOTOR			
Frequency controlled		standard	standard
EXTRACTION SPEED	rpm	1150	1100
G-FACTOR		390	360
ELECTRICAL CONNECTION		1×220-240V 50/60Hz 3×220-240V 50/60Hz 3×380-400V 50/60Hz 1×380-400V 50/60Hz	
ELECTRICAL HEATING	kW	Standard 6kW Optional 3 or 9kW	
WATER CONNECTION			
Warm water max. 70 °C		3/4"	
Cold water connection		3/4"	
DRAIN			
Drain valve		standard	
Pump		available	
DIMENSIONS			
H×W×D	mm	940×685×645	940×685×685
TRANSPORT DATA			
Gross weight			
Foil packing	kg	165	175
Net weight	kg	160	165
Volume (packed)			
Foil packing	m ³	0,54	0,59
Foil packing			
H×W×D	mm	1060×710×740	1060×710×740
WATER CONSUMPTION			
Cold and hot water per cycle*	l	40+8	48+12

* Tested in accordance of EN 604 56 norm
The data concerning dimensions of machines include all extended parts

TYPE		DAM9	DAMS9
CAPACITY	kg	8,5 kg	
DRUM DIAMETER	mm	Ø650	
DRUM VOLUME	l	184	
DOOR OPENING	mm	525	
ELECTRICAL CONNECTION		1×220-240V 50/60Hz 3×220-240V 50/60Hz 3×380-400V 50/60Hz Others on request	
GAS CONNECTION	Inch	3/8	N/A
ELECTRICAL HEATING	kW	5kW/1AC-3AC	
GAS HEATING	kW	6,2	N/A
MOTOR POWER	kW	0,249	
AIRFLOW	m ³ /min.	6	
DIMENSIONS			
H×W×D	mm	1092×683×711	914×683×711
TRANSPORT DATA			
Gross weight			
Cardboard packing	kg	63	63
Net weight	kg	57	57
Volume (packed)			
Cardboard packing	m ³	0,66	0,66
Cardboard packing			
H×W×D	mm	1150×770×750	1150×770×750

P6, P7

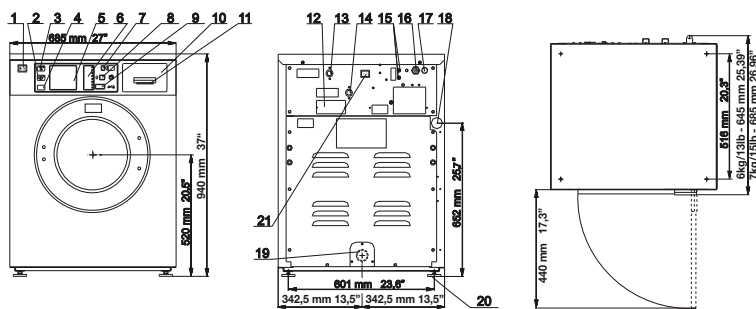

DAMT9

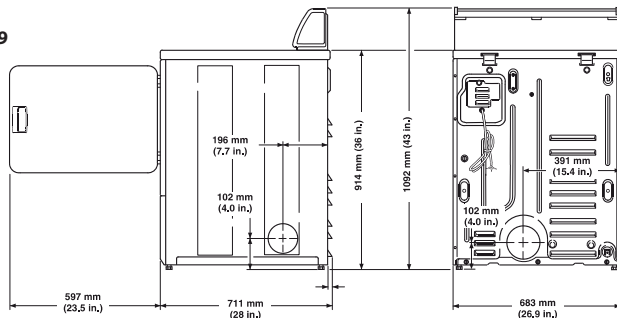

1. Electrical switch
2. Function push button
3. START push button
4. Door open push button
5. Card of programs
6. LED of cycle indicators
7. LED of program display
8. LED of remaining time display
9. LED of option temperature display
10. Soap hopper
11. Drum venting
12. Serial plate
13. Connection of cold water
14. Connection of hot water
15. Fuses
16. Electrical connection of the machine
17. Plug
18. Hose orifice of the version with drain
19. Drain of the version with drain valve
20. Adjustable leg
21. „Program/run“ mode push button

The company Primus preserves the right to change the machines and the specification in this leaflet at any time, without prior notice. Details and photographs are only for information and never binding.

www.primuslaundry.com

ISO 9001
ISO 14001

BUREAU VERITAS
Certification

